

105

TECHNICAL REPORT

Assembly of rear crankshaft
seal 61002200 in 2.5-2.8 CRD
Chrysler engines



01

SCOPE

Report about the **two possibilities of rear crankshaft seal assembly** (transmission end) which part number is 61002200 and it is used in Chrysler, Jeep and Dodge 2.5-2.8 CRD engines from year 2000 to 2008.

02

DESCRIPTION

Due to these engines design, in case of **being necessary to extract the crankshaft from engine block**, this one will not extract down, like most of cases, if not it will be extracted sideways, to the gearbox side.



Due to this peculiarity, engine has, at the end of gearbox side, a **last bearing which can be extracted**. This one also can be extracted when oil seal is necessary to be changed and for this reason, it also **will be necessary to change the next components** that are showed now:

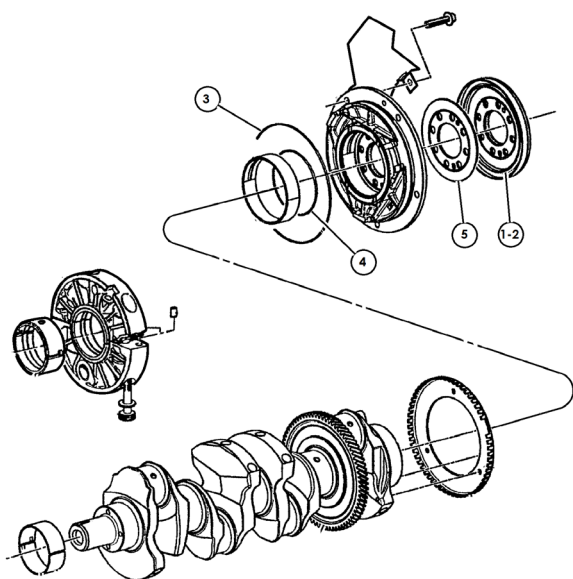

OIL SEAL COMPOSITION 61002200

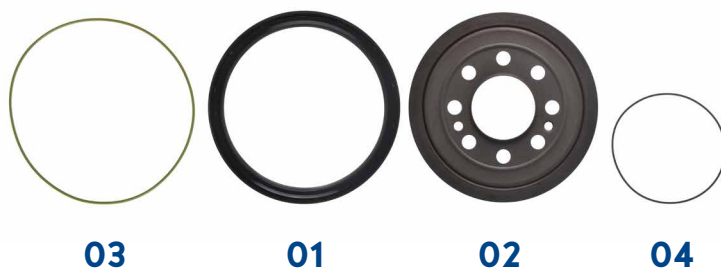

- 01 Oil seal
- 02 Metal sheet disc
- 03 Bearing-engine block o-ring
- 04 Metal disc-shaft o-ring
- 05 Machining disc

2 POSSIBLE DESIGNS OF PIECE #2 AND #5:

The oil seal that is mounted in this place not only must seal the circular surface of rotational shaft if not **it must seal the front of the shaft too.**

For it, it has a **metal disc** which rotates with him. Inside of the disc design, we can find two possibilities. Depending on which one is assembled, we must assembly some components or others.

MACHINIG DISC

METAL SHEET DISC



Elastomer rib

04

In this case, to seal against the shaft, **an o-ring accommodated in a groove** of the disc is used. In this case, disc can be re-used and for it, it is not included with our oil seal. o-ring does be included.

It is made in sheet of 1 mm of thickness and over it, the **elastomer rib is injected against** crankshaft. This component does be necessary to be replaced.

This metal sheet **is necessary to be changed**. For this reason, it is included with our oil seal.

03

ASSEMBLY

1. **Clean shaft and housing surfaces**, leaving them free of grease, oil, and dirt.
2. **O-ring installation #3** in the bearing and installation of this one over engine block with a tightening bolts of 2 Kpm (20 Nm).



3. **Oil seal installation using** the specific tool (VM.1050) to collocate it in his housing. This tool collocates the oil seal to the desire depth in respect of housing.



4. Disc installation of the appropriate design. **Mechanising disc + o-ring or metal sheet disc.**

5. **Collocation of the rest of the components.** Flywheel, metal sheet and bolts. Tightening of 2.5 Kpm + 60 degrees (25 Nm + 60 degrees).

