

APPLICATIONS: Nissan, Opel/Vauxhall, Renault 2.0L Diesel (M9R) - 2006>

There are key differences between **HG1450** and **HG1770** head gaskets.

Ensure you identify and order the correct component for your specific application.

For full application details and technical information, **visit faiauto.com/ecat**

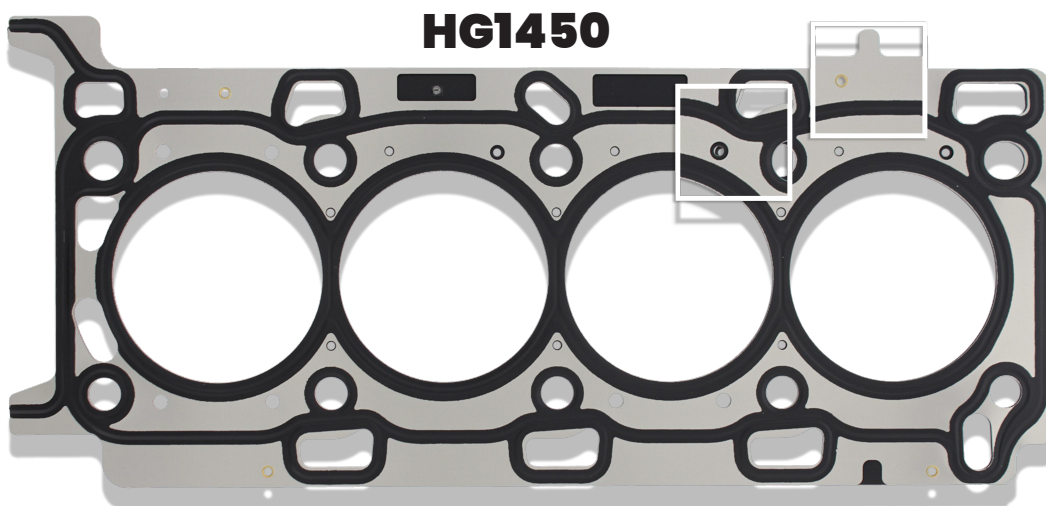

8mm Tab | 2.9mm Diameter

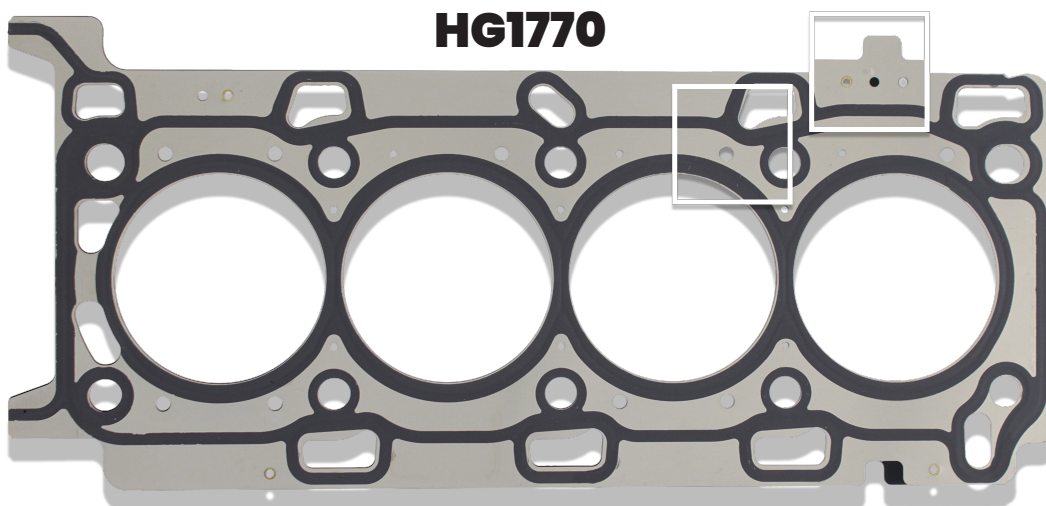

16mm Tab | 6mm Diameter

FAI products are designed for use in standard, unmodified vehicles and are not intended for custom or altered applications. All components must be installed by a qualified technician.

Please note: FAI products are supplied without fitting instructions.

For more information, email technical@faiauto.com

faiauto.com